

THIS DRAWING IS UNPUBLISHED. RELEASED FOR PUBLICATION, 19 .  
 © COPYRIGHT 19 BY AMP INCORPORATED. ALL INTERNATIONAL RIGHTS RESERVED.

LOC	DIST	P	F	ZONE	LTR	DESCRIPTION	DATE	APPD
CE	16				O	NPR 88-57		
					C	REV PER 0A00-0588-03	26MAR04	KG/SB
					-	-	-	-

PART NUMBER	KEYING TYPE	
501805-1	A TO B	
501805-2	M TO S	
501805-3	A TO B	OBSOLETE $\triangle 2$
501805-4	M TO S	OBSOLETE $\triangle 2$

1. DIMENSIONS IN [ ] ARE IN INCHES.  
 $\triangle 2$  INDIVIDUALLY PACKAGED

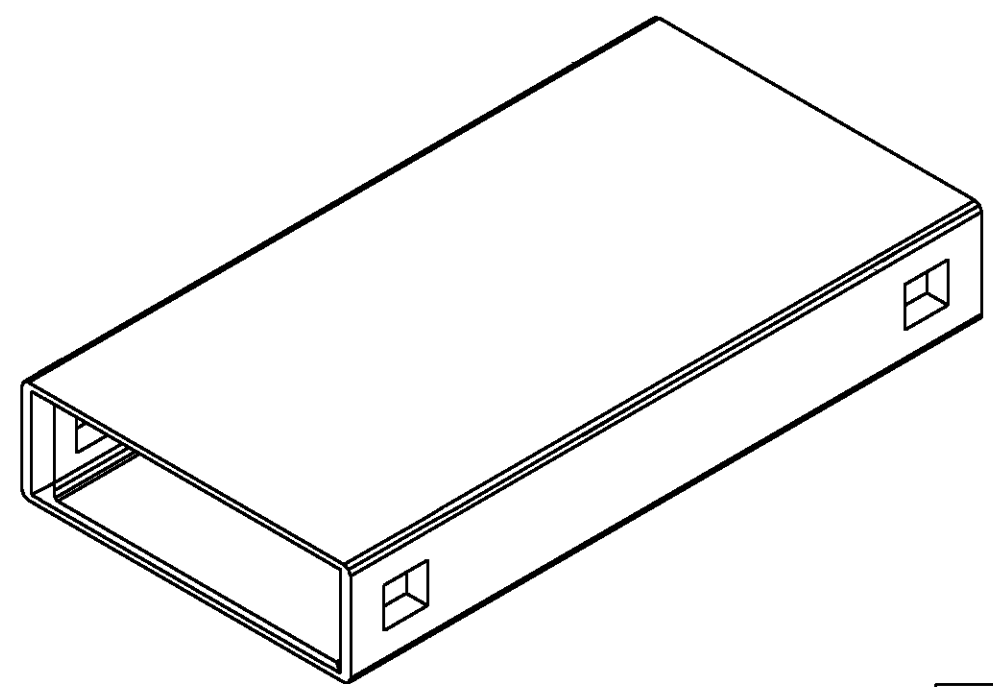
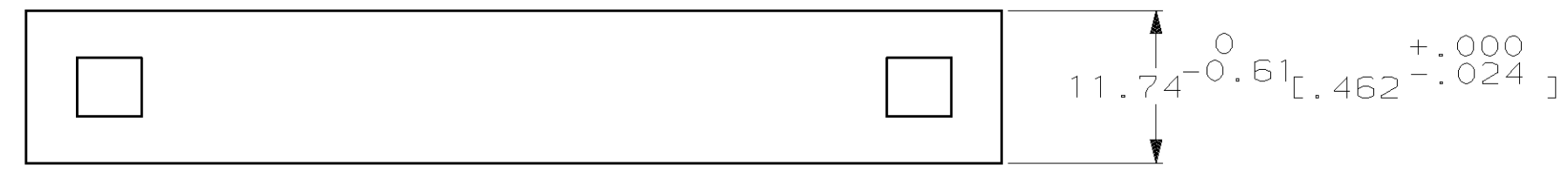
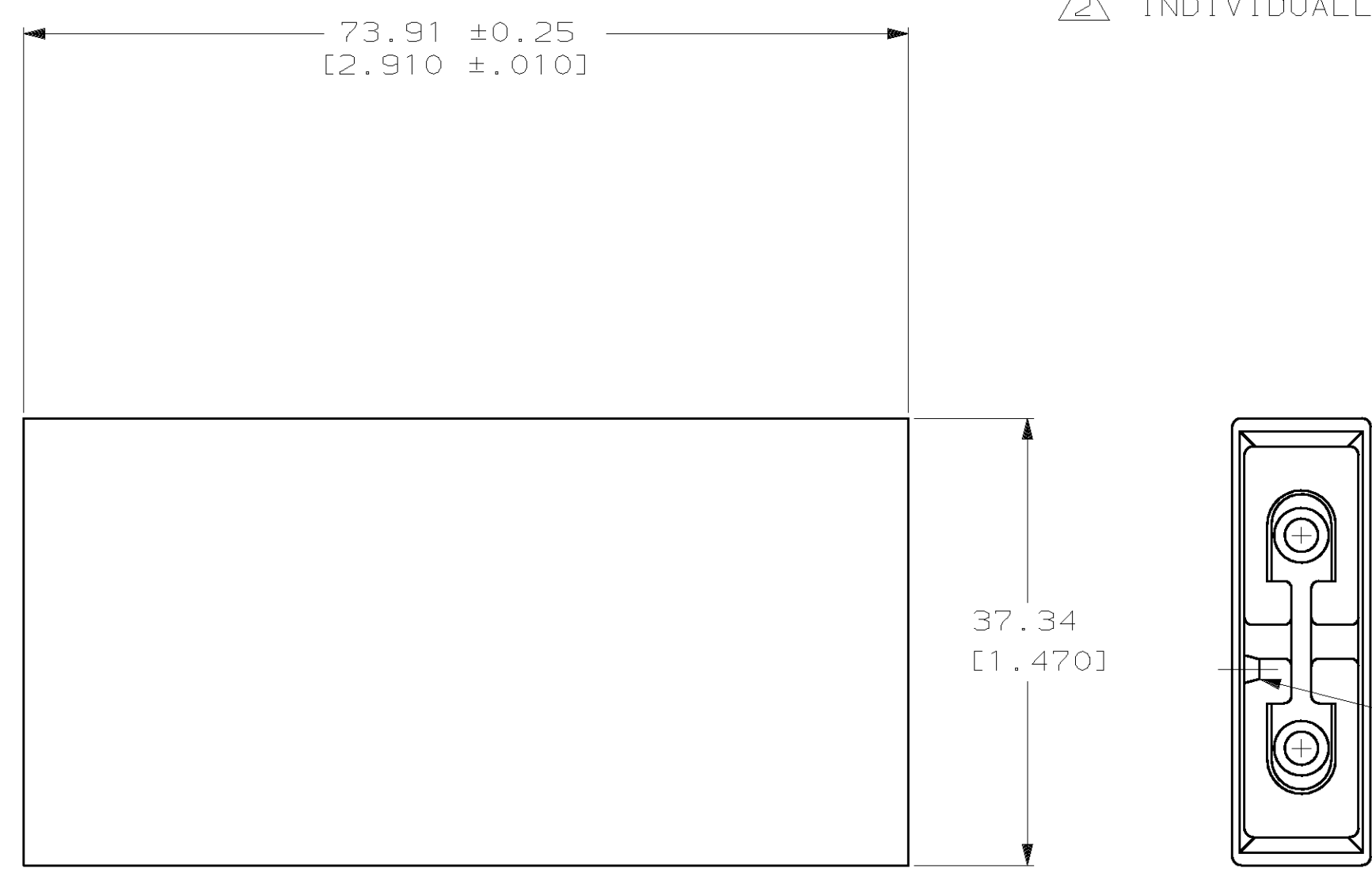

METRIC

RESTRICTED RELEASE  
 DRAWING MAY CHANGE WITHOUT  
 CUSTOMER NOTIFICATION

DO NOT SCALE PRINT. UNLESS SPECIFIED DIMENSIONS IN mm TOLERANCES ON : 2 PLC DEC ± 0.13(.005) 3 PLC DEC ± - ANGLES ± -		DR 4-23-88 D. KNOWLDEN	PART NO	
MATERIAL PBT MOLDING COMPOUND	CHK 4-23-88 B. BRIGGS	APPD 4-23-88 D. THOMPSON	AMP INCORPORATED Harrisburg, Pa. 17105	
FINISH -	APPD 4-23-88 R. WEBER	PRODUCT SPEC -	NAME DUPLX TO DUPLX COUPLING ASSEMBLY, WITHOUT MOUNTING EARS, AMP FSD	
APPLICATION SPEC -	WEIGHT -	SIZE C	FSCM NO 00779	DRAWING NO 501805
		SCALE 2:1	SHEET 1 OF 1	